

The GLE

Sport Utility Vehicle



Mercedes-Benz



A black SUV is driving away from the viewer on a two-lane asphalt road that curves to the right. In the distance, a railroad crossing with two red lights and a white barrier is visible. The landscape is a dry, desert-like environment with sparse vegetation and mountains in the background under a blue sky with scattered clouds. The road has white painted markings, including the word 'STOP' in large letters in the foreground.

The shape of success.
In a whole new dimension.

More intelligent and attentive than ever – the new GLE casts the SUV in a whole new light.



RAILROAD
CROSSROAD

D S UV 1670





Consummate design from any angle.

Take a step back at the right moment and then be right there when it matters the next moment – that is the art of the GLE design. The optional AMG Line lends the new GLE an emphatically sporty appearance.



Follow your intuition.

The new GLE is the first SUV to feature the revolutionary MBUX infotainment system. It includes a natural voice control system and a touchscreen. And it learns more about the driver's habits and preferences on every trip.





The image shows the interior of a Mercedes-Benz GLE SUV, specifically the second row of seats. The seats are upholstered in a light-colored, possibly leather or leatherette material, with a quilted pattern on the backrests. The seats are positioned in a way that suggests a spacious and comfortable environment. The background shows the side window and the interior door panel, which are also finished with a light-colored material. The overall lighting is soft and even, highlighting the texture and contours of the seats.

More space for an imposing interior.

For the first time, the GLE is now available with a third seat row with two full-size seats. Access to the third row is easy, while the flexibility provided by an adjustable second seat row makes the footwell very adaptable. And what's even better is that the improved spatial concept of the new GLE still provides more legroom and comfort in the rear.



Quiet, please. For one of the world's
most sophisticated suspension systems.

The new GLE is effortlessly superior on any terrain. But the new E-ACTIVE BODY CONTROL suspension takes the comfort to a whole new level.



S UV 1672



MBUX Augmented Reality Navigation.

To enable you to find your way in complex traffic situations, MBUX Augmented Reality Navigation connects the virtual world with the real world. The technology incorporates graphical navigation instructions and traffic information into live images. You can get to your destination quickly, safely and stress-free.



ENERGIZING package Plus.

The ENERGIZING package Plus is a new feature – it offers comfort at the highest level for all the senses. To this end, a maximum of premium features are combined with innovative intelligence. The result is quite fascinating: your Mercedes can vitalise and cosset you in specific ways. For prolonged alertness at the wheel and a very pleasant drive.

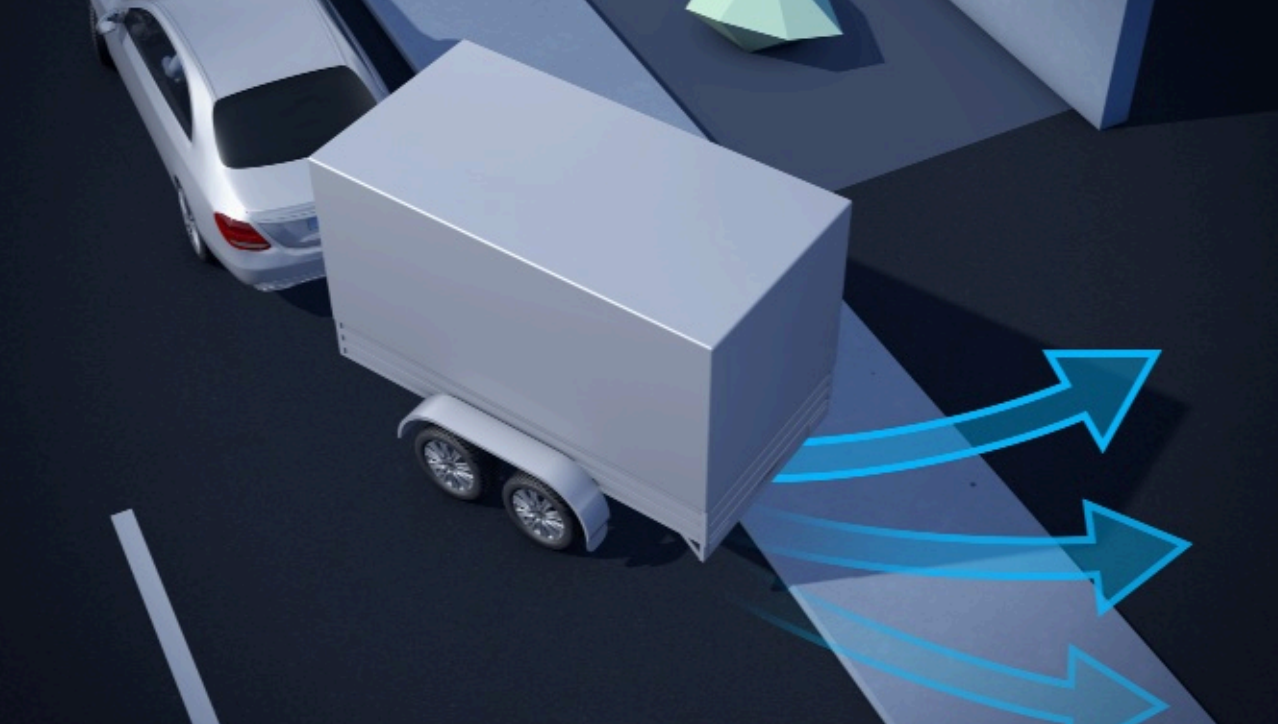

Trailer Manoeuvring Assist.

Save time and spare your nerves when manoeuvring: with Trailer Manoeuvring Assist you can complete reversing manoeuvres calmly, confidently and precisely – even in difficult situations. For inexperienced drivers of car/trailer combinations in particular, the assisted steering is a genuine help.



Head-up display.

The best outlook for sporty driving enjoyment and an assured driving experience: the head-up display transforms your windscreen into a stunning digital cockpit. As such you always have a direct view of key information. Your full attention remains on the road and the traffic conditions in front of you.



3rd seat row for 2 persons.

The seats and cargo volume available in your vehicle are just as diverse as your lifestyle. The third seat row for two additional passengers can be quickly folded up or down at any time. Use the flexibility to suit your specific needs – depending on whether you wish to transport other passengers or a large amount of luggage.



Electrically adjustable rear seats.

The electrically adjustable second seat row brings a convenient level of flexibility: extend the load space at the simple touch of a button and position the rear seats as you require them. It all makes for a quick and easy way to create extra load capacity.



Widescreen Cockpit.

Design that impresses, right from the start: the elegant Widescreen Cockpit. And the more you explore, the better it gets: choose between four different display styles, follow the navigation guidance provided by MBUX Augmented Reality Navigation, position the desired content according to your individual wishes. All on two large 31.2 cm (12.3-inch) displays under a stylish glass cover.



Burmester® high-end 3D surround sound system.

Sound on a par with that of luxury home music systems. Speakers in the roof liner compose a three-dimensional sound. They conduct the system like your personal orchestra – with VIP settings for individual seats or style settings such as “Live” or “Easy Listening”.

Standard equipment and appointments.

Powerful vehicle with powerful character: the exterior conveys strength and elegance. The generous proportions exude effortless superiority and safety.

The progressively designed interior embodies a sense of sporty elegance. Generous dimensions, high-quality materials and a host of useful details form the basis for a luxurious atmosphere and comfortable travel.



The AMG Line design and equipment line.

The optional AMG Line adds a shine with a sparkling diamond radiator grille. Sporty aprons all round, large air inlets, painted wheel arch liners and special light-alloy wheels demonstrate a sporting style.

AMG Line features add a touch of racing style to the interior and support dynamic driving.

EXCLUSIVE interior.

The EXCLUSIVE interior allows you to show what matters to you: the utmost in elegance and top-class quality down to the most minute detail. The luxurious highlights and fine ambience of your interior will bring you a whole new sense of joy every day and reflect your good taste.



Night package.

More character – expressive style. In combination with the AMG Line, the Night package adds striking highlights in the form of exclusive black design features. These accentuate the sporty character and athletic design idiom of your vehicle. Ideal for individualists who appreciate an expressive design.





Driving Assistance package Plus.

The optionally available Driving Assistance package Plus tangibly reduces the strain on the driver, particularly on long trips but also in confusing urban traffic. The new GLE is available with the very latest generation of this package, which can now provide support

in even more driving situations: for example in a traffic jam or in advance of bends, roundabouts or junctions. The new GLE can follow the vehicle in front even in stop-and-go traffic. This also relieves the driver of the bothersome task of restarting after each stop.



E-ACTIVE BODY CONTROL fully active suspension.

With the new E-ACTIVE BODY CONTROL fully active air suspension we are pooling our most innovative and intelligent suspension technologies to create a mesmerising driving experience.

In “Curve” mode, the vehicle can actively lean into a bend. This minimises the transverse force and tangibly increases comfort and dynamism. In “Comfort” mode, the ROAD SURFACE SCAN with stereo camera scans the road ahead of the vehicle. The suspension struts are then activated so as to substantially reduce the body movements when driving over bumps in the road.

Not an SUV. An AMG.

Every Mercedes-AMG is a masterpiece in its own right, with an unmistakable character. What unites our performance vehicles and sports cars is their irrepressible sporting spirit. Their passion for top performance. It is generated at the point where engineering skill meets a very special attitude: the spirit of AMG. We believe that you have to keep on challenging limits in order to achieve new goals. We accept nothing as a given. Because limits are imposed by people, and it's also people who can overcome them. It's this attitude that enables us to achieve outstanding performance for the race track – and for the road.

Welcome to the world of AMG.

www.mercedes-amg.com

DRIVING PERFORMANCE





Technical data.

Displacement (cc)
Rated output ¹ (kW [hp] at rpm)
Acceleration from 0 to 100 km/h (s)
Top speed (km/h)
Fuel consumption ⁴ (l/100 km)
Urban
Extra-urban
Combined
Combined CO ₂ emissions ⁴ (g/km)
Emissions class ⁵ /efficiency class ⁶

Displacement (cc)
Rated output ¹ (kW [hp] at rpm)
Acceleration from 0 to 100 km/h (s)
Top speed (km/h)
Fuel consumption ⁴ (l/100 km)
Urban
Extra-urban
Combined
Combined CO ₂ emissions ⁴ (g/km)
Emissions class ⁵ /efficiency class ⁶

Petrol engines

GLE 450 4MATIC	GLE 580 4MATIC	Mercedes-AMG GLE 53 4MATIC+	Mercedes-AMG GLE 63 4MATIC+	Mercedes-AMG GLE 63 S 4MATIC+
2.999	3.982	2.999	3.982	3.982
270 [367] / 5.500-6.100	360 [489] / 5.500	320 [435] / 6.100	420 [571] / 5.750-6.500	450 [612] / 5.750-6.500
5,7	4,9	5,3	4,0	3,8
250 ³	250 ³	250 ³	250 ³	250 ³
12,6-10,5	12,4-12,0	11,6-11,6	15,3-15,3	15,3-15,3
7,6-6,9	8,7-8,1	7,9-7,9	9,2-9,2	9,3-9,3
9,4-8,3	10,1-9,5	9,3-9,3	11,4-11,4	11,5-11,5
214.0-190.0	230.0-217.0	212.0-212.0	261.0-261.0	262.0-262.0
Euro 6d-TEMP-EVAP-ISC / C	Euro 6d-TEMP-EVAP-ISC / C	Euro 6d-TEMP-EVAP-ISC / C	Euro 6d ISC-FCM / E	Euro 6d ISC-FCM / E

Diesel engines

GLE 300 d 4MATIC	GLE 350 d 4MATIC	GLE 400 d 4MATIC	Plug-in hybrid (diesel) GLE 350 de 4MATIC
1.950	2.925	2.925	1.950
180 [245] / 4.200	200 [272] / 3.200	243 [330] / 3.600	
7,2	6,6	5,7	6,8
225	230	245	210
7,3-7,0	9,9-8,4	9,7-8,5	
5,9-5,4	6,0-5,6	6,2-5,6	
6,4-6,1	7,4-6,7	7,6-6,8	1,3-1,1/28,7-25,4*
169.0-161.0	195.0-177.0	199.0-179.0	34.0-29.0
Euro 6d ISC / A	Euro 6d ISC-FCM / B	Euro 6d ISC-FCM / B	Euro 6d ISC-FCM / A+

The best for the engine:
Mercedes-Benz genuine engine oils.

¹ Information about the rated output according to Regulation (EC) No. 715/2007 in the currently valid version. ² Available temporarily. ³ Electronically governed. ⁴ The stated figures were determined according to the prescribed measurement method. They constitute the "NEDC CO₂ figures" pursuant to Article 2 No. 1 Implementing Regulation (EU) 2017/1153. Fuel consumption figures have been calculated on this basis. More information about the official fuel consumption and the official specific CO₂ emissions of new passenger cars is available in the publication entitled "Leitfaden über den Kraftstoffverbrauch, die CO₂-Emissionen und den Stromverbrauch neuer Personenkraftwagen" ["Guidelines concerning the fuel consumption, CO₂ emissions and electricity consumption of new passenger cars"], available free of charge at all retailers and from Deutsche Automobil Treuhand GmbH (www.dat.de). The figures are not based on an individual vehicle and do not constitute part of the product offer; they are provided solely for purposes of comparison between different vehicle models. The figures will vary according to the optional equipment selected. ⁵ Information only valid within the European Union. May vary from country to country. ⁶ Determined on the basis of the measured CO₂ emissions, taking into consideration the vehicle mass. Only valid for Germany. *Weighted electrical consumption (kWh/100 km).

Further technical data may be found at www.mercedes-benz.com.cy

Dimensions.

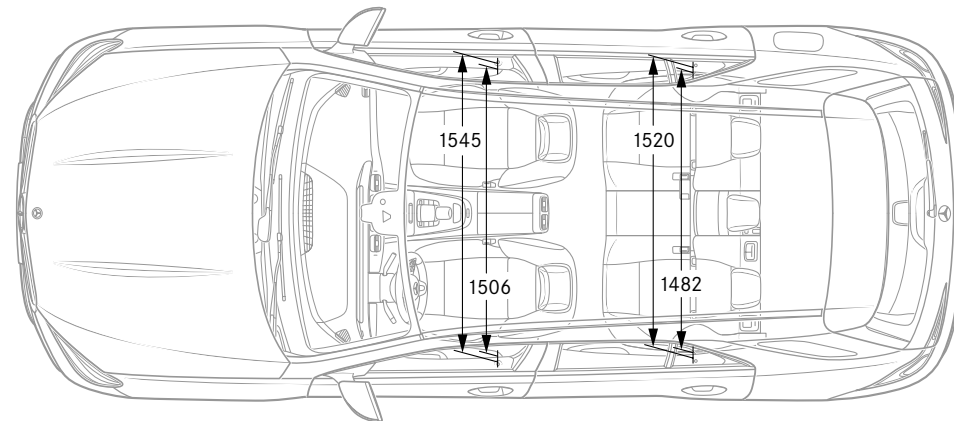
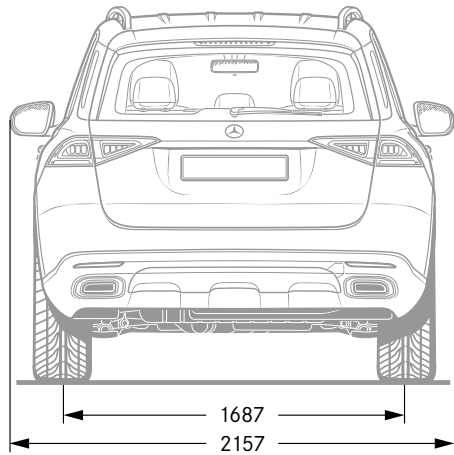
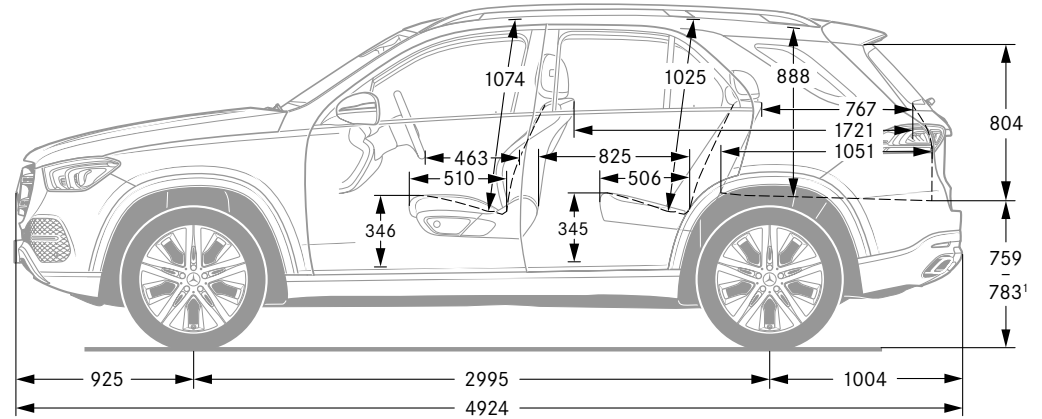
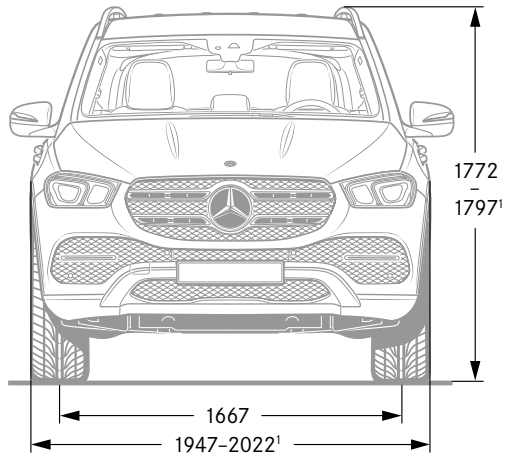

¹ At minimum to maximum height with steel suspension. All figures in millimetres. The illustrated dimensions are mean values. They are valid for vehicles in basic specification and in unladen condition.



SPORT - F O R - GOOD

Mercedes-Benz AG is one of the founding partners of the worldwide “Laureus Sport for Good Foundation”, which was established in 2000. It is the Mercedes-Benz brand’s most important social initiative. Laureus Sport for Good supports children and young people in need through social sports projects, opening up new perspectives and imparting important values such as team spirit, respect and determination. “Change the Game for Kids” is our mission statement which we wish to share with you.

Please note: Changes may have been made to the product since the editorial deadline on 24.03.2020. The manufacturer reserves the right to make changes to the design, form, colour and the product specification during the delivery period, provided these changes, while taking into account the interests of the seller, can be deemed reasonable with respect to the buyer. Where the seller or the manufacturer uses symbols or numbers to describe an order or the

subject of an order, no rights may be derived solely from these. The illustrations may show accessories and items of optional equipment which are not part of standard specification. For the definitive latest information, please contact your nearest authorised Mercedes-Benz AG dealer.