

The GLC Coupé



Mercedes-Benz





More than an SUV.
More than a coupé.
More than ever before.

Some personalities immediately make their mark. With their appearance. Their self-assurance. And their unique character. Much like the GLC Coupé, which combines the merits of an SUV and a coupé like no other. In a style all of its own. More dynamic and sportier than ever.





AMG
MERCEDES-BENZ
C127
C127
C127



The image shows the interior of a Mercedes-Benz GLC Coupé, focusing on the driver's side door panel and the center console. The door panel features a circular air vent, a speaker, and a control panel with buttons for window and mirror adjustments. The center console has a gear shifter and handbrake. The interior is finished with black leather and brown leather accents. The text "Because communication is everything today." is overlaid on the image.

Because communication
is everything today.

As well as understanding what you say, the GLC Coupé responds instantly to your touches and gestures. This is thanks to MBUX, the sophisticated Mercedes-Benz User Experience, which boasts a wealth of control and display features. Like the large media display with touch function or the fully digital instrument cluster with navigation display.





Something special. On every trip, from any angle.

The GLC Coupé is eye-catchingly sporty like never before. With wider aprons, distinctive tailpipe trims and, fitted as standard for the first time, LED High Performance headlamps with a sophisticated light design. The optional AMG Line and a host of wheel designs take its unique sporty and elegant character to the highest level.

The rear end: The start of something new.

The GLC Coupé's rear end is appealingly athletic and sporty. Powerful contours combine here with sensual, pure lines to dynamic effect. The impressive apron, the stylish chrome elements and the tailpipe trims integrated into the bumper all catch the eye. The slender LED tail lights with their cutting-edge light design are particularly striking.







Sit in an SUV.
Drive a sports coupé.

Every metre and every second become a sporting event in the GLC Coupé. You can make the GLC Coupé even more agile with the optional DYNAMIC BODY CONTROL suspension, which lets you individualise the vehicle's damping and handling characteristics. At the touch of a button, for a noticeably more comfortable or more dynamic driving experience. Three modes are available for this: "Comfort", "Sport" and "Sport+",





Energising comfort and exemplary safety.

Be it at rush hour, during a long drive at night or on an unfamiliar route, your GLC Coupé noticeably takes the strain off you, particularly in stressful situations. It's all down to a concept that makes every journey in a Mercedes-Benz a safer and unique experience: Mercedes-Benz Intelligent Drive. Because the time you spend behind the wheel is your time. Time for relaxation. Time to replenish your energy. So that, first and foremost, you reach your destination safely, but are also relaxed when you get there.



EQUIPMENT HIGHLIGHTS – DRIVING ASSISTANCE SYSTEMS

Driving Assistance package. Join the road to autonomous driving: cutting-edge systems support you according to the given situation with speed adjustment, steering, lane changes and even when there is a risk of collision. The risk of an accident is reduced – passengers and road users are protected effectively. This way you are able to reach your destination safely and feeling relaxed.

The innovative **PRE-SAFE® Sound** system generates a sound signal through the loudspeakers that can trigger a protective reflex: your auditory system briefly disconnects, thereby protecting itself from the loud noise of a crash.

Parking package with 360° camera. Optimum parking service on board. Active Parking Assist with 360° camera makes it easier for you to find a parking space and to manoeuvre into and out of parking spaces. The choice here is yours: park with ease yourself thanks to excellent all-round visibility – or make things even easier still by getting the car to park for you.



Mercedes-Benz User Experience.

In the GLC Coupé, you can now control almost everything as intuitively as you do on your smartphone. Simply by using the large touchscreen, the touchpad, or the Touch Control buttons on the steering wheel. One touch is all it takes to adjust the display style, the ambient lighting, or the infotainment to meet your needs.



EQUIPMENT HIGHLIGHTS – CONTROL AND DISPLAY CONVENIENCE

To enable you to find your way in complex traffic situations, **MBUX Augmented Reality Navigation** merges the virtual world with the real world. The technology incorporates graphical navigation instructions and traffic information into live images. So you reach your destination quickly, safely and stress-free.

With the **MBUX voice control** option, the GLC Coupé not only listens to you, it hangs on your every word and talks to you. You can converse with your car in a perfectly natural manner to adjust and control virtually all the functions in the car. Simply say “Hey Mercedes”, and the GLC Coupé will be all ears.



Fully digital instrument cluster.

The fully digital instrument display with the “Classic”, “Progressive” and “Sporty” display styles enables you to decide which information is important to you and how you wish to see it displayed. The 31.2 cm (12.3-inch) display delivers a pin-sharp image which is easy to read in all light conditions.

Burmester® surround sound system.

With the optional Burmester® surround sound system your GLC Coupé becomes a concert hall. 13 high-performance speakers, a 9-channel DSP amplifier, a total system output of 590 W and electronic and acoustic elements tailored precisely to the interior conjure up a unique sound. The surround function and the sound optimisation for the front and rear seats provide an even more intensive listening experience.



MULTIBEAM LED headlamps.

Giving you perfect visibility: the adaptive MULTIBEAM LED headlamps with individually controllable LEDs react to the traffic situation. Partial main beam masks out other road users without dazzling them. ULTRA RANGE Highbeam increases the range to the permitted maximum. The cornering and active light functions also light up the field of vision in optimal style.



Sporty wheel design.

There's no stopping the GLC Coupé – it is forever evolving. An even broader range of exclusive wheels is now available, offering a wide variety of rim designs. From 45.7 cm (18 inches) to 50.8 cm (20 inches), from elegant to sporty: the choice is yours.

Standard equipment and appointments.

A stylish exterior all round already awaits you with the standard equipment. This includes exclusive design features in chrome and attractive light-alloy wheels. The visible, chrome-plated tailpipe trim elements underline the dynamic look of the vehicle.



The EXCLUSIVE Interior design and equipment line.

The EXCLUSIVE Interior allows you to show what matters to you: the utmost in elegance and top-class quality down to the most minute detail. The luxurious highlights and fine ambience of your interior, including exclusively styled seats and an elegantly upholstered instrument panel, will bring you fresh pleasure every day.

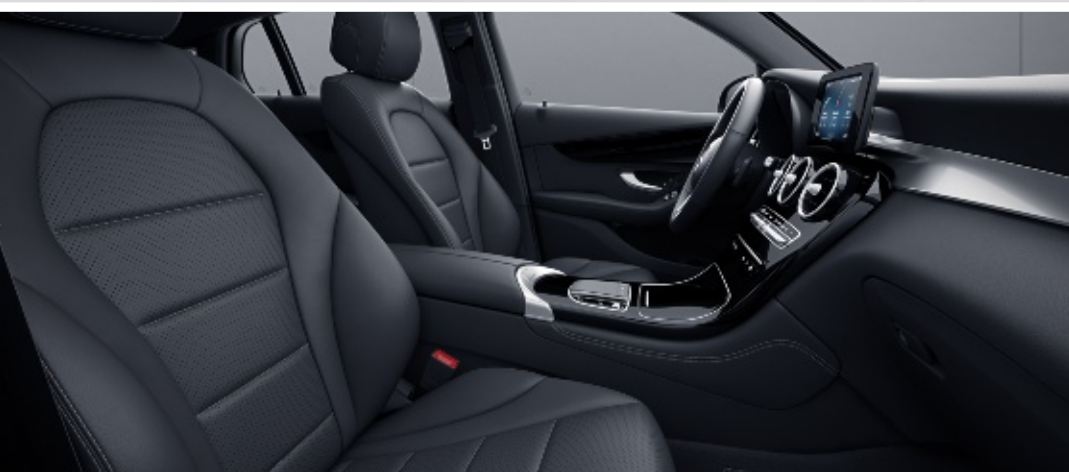

The AMG Line.

The expressive bodystyling of the AMG Line lends the exterior a sporty, exclusive touch. As such you can make a clear statement for powerful design. The technical features additionally provide you with more tangible driving pleasure, as the sports suspension – tuned for agility and coupled here with the Sports Direct-Steer system – ensures emphatically dynamic handling.



The Night package.

The Night package adds attractive touches: many of the exterior features are finished in black. They underscore the sporty character and special individuality of your vehicle. And as such you can demonstrate your sense of expressive design and exclusive sportiness.





DYNAMIC BODY CONTROL.

With the optional DYNAMIC BODY CONTROL suspension you can adapt the GLC Coupé's damping and handling characteristics to your individual needs. At the touch of a button, for a noticeably more comfortable or more dynamic driving experience. Three modes are available for this: "Comfort", "Sport" and "Sport+", According to whether you are looking for particularly comfortable, sporty or extra-sporty handling. The damping is continuously variable and is adjusted individually for each wheel. For even better driving safety and ride comfort.

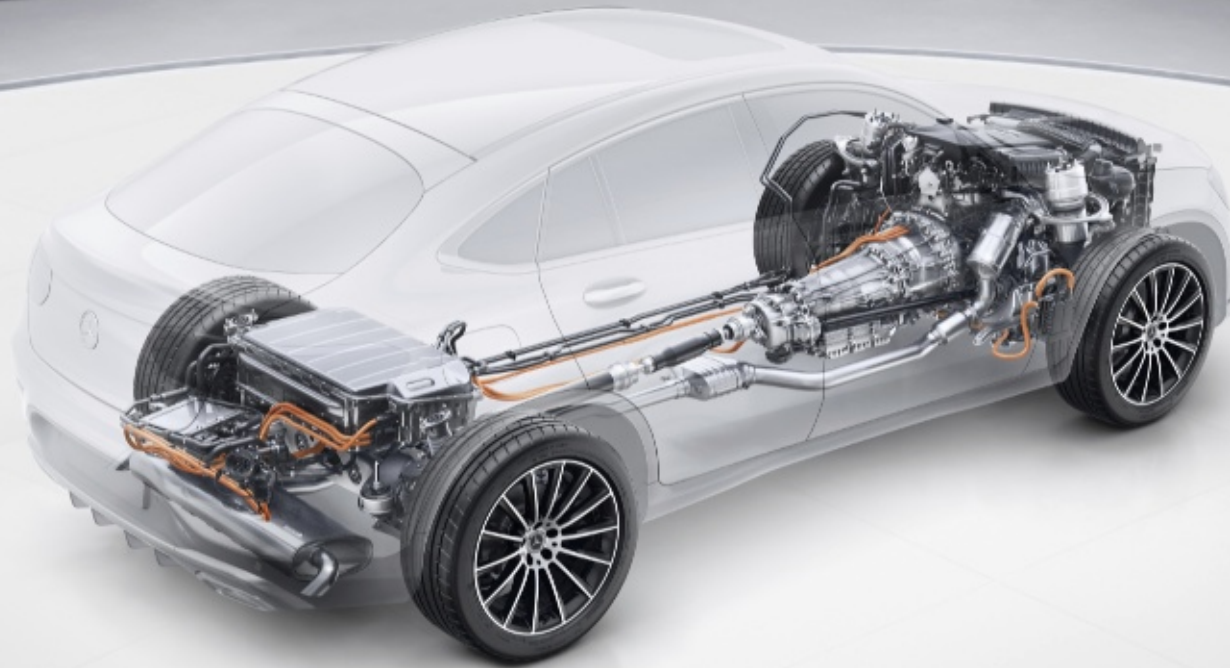

4MATIC all-wheel drive.

On tarmac or light off-road terrain: with 4MATIC, the GLC Coupé shows its special strengths in adverse weather conditions such as rain, black ice or snow. Thanks to the interplay between the individual wheels, the permanent all-wheel drive is able to provide exemplary driving stability and traction. For greater dynamism, comfort and safety overall.

Not an SUV. An AMG.

Every Mercedes-AMG is a masterpiece in its own right, with an unmistakable character. What unites our performance vehicles and sports cars is their irrepressible sporting spirit. Their passion for top performance. It is generated at the point where engineering skill meets a very special attitude: the spirit of AMG. We believe that you have to keep on challenging limits in order to achieve new goals. We accept nothing as a given. Because limits are imposed by people, and it's also people who can overcome them. It's this attitude that enables us to achieve outstanding performance for motor racing – and for the road.

Welcome to the world of AMG.

www.mercedes-amg.com



AMG
DRIVING PERFORMANCE



Technical data.

Displacement (cc)
Rated output ¹ (kW [hp] at rpm)
Acceleration from 0 to 100 km/h (s)
Top speed (km/h)
Fuel consumption ⁴ (l/100 km)
Urban
Extra-urban
Combined
Combined CO ₂ emissions ⁴ (g/km)
Emissions class ⁵ /efficiency class ⁶

Displacement (cc)
Rated output ¹ (kW [hp] at rpm)
Acceleration from 0 to 100 km/h (s)
Top speed (km/h)
Fuel consumption ⁴ (l/100 km)
Urban
Extra-urban
Combined
Combined CO ₂ emissions ⁴ (g/km)
Emissions class ⁵ /efficiency class ⁶

Petrol engines

GLC 200 4MATIC	GLC 300 4MATIC	Mercedes-AMG GLC 43 4MATIC	Mercedes-AMG GLC 63 4MATIC+	Mercedes-AMG GLC 63 S 4MATIC+	Plug-in hybrid GLC 300 e
1.991	1.991	2.996	3.982	3.982	1,991 / 48.0-52.0 km
145 [197] / 5.500-6.100	190 [258] / 5.800-6.100	287 [390] / 5.500-6.100	350 [476] / 5.500-6.250	375 [510] / 5.500-6.250	155 [211]/5.500-5.500 90 [122] / 2.500 kW
8,0	6,3	4,9	4,0	3,8	5,7
216	240	250 ³	250 ³	280 ³	230
9,6-8,9	9,6-8,9	14,1-13,6	17,3-16,8	17,1-16,8	
7,3-5,9	7,3-5,9	8,6-8,1	9,5-9,0	9,4-9,2	
8,1-7,0	8,1-7,0	10,5-10,2	12,3-12,1	12,3-12,1	2,5-2,2 / 167.0m.math
186.0-161.0	186.0-161.0	240.0-232.0	280.0-275.0	280.0-277.0	57.0-49.0
EURO 6D-ISC-FCM / B	EURO 6D-ISC-FCM / B	EURO 6D-ISC-FCM / F	EURO 6D-ISC-FCM / G	EURO 6D-ISC-FCM / G	EURO 6D-ISC-FCM / A+

Diesel engines

GLC 200 d 4MATIC	GLC 200 d	GLC 220 d 4MATIC	GLC 300 d 4MATIC	GLC 400 d 4MATIC	Plug-in hybrid GLC 300 de 4MATIC
1.950	1.950	1.950	1.950	2.925	1.950
120 [163] / 4.200-4.600	120 [163] / 3.200-4.600	143 [194] / 3.800-3.800	180 [245] / 4.200-4.200	243 [330] / 3.600-4.200	143 [194]/3.800-3.800 90 [122] / 2500 kW
8,9	8,7	7,9	6,6	5,1	6,2
206	208	217	233	240	230
6,6-5,7	6,3-6,1	6,6-5,7	7,4-7,0	8,6-8,1	
5,6-4,8	4,7-4,4	5,6-4,8	5,4-5,0	5,6-5,2	
6,0-5,2	5,3-5,0	6,0-5,2	6,0-5,7	6,6-6,3	2,0-1,9 / 156m.math
158.0-136.0	140.0-132.0	158.0-136.0	159.0-152.0	175.0-167.0	52.0-45.0
EURO 6D-ISC-FCM / A	EURO 6D-ISC-FCM / A	EURO 6D-ISC-FCM / A	EURO 6D-ISC-FCM / B	EURO 6D-ISC-FCM / B	EURO 6D-ISC-FCM / A+

The best for the engine:
Mercedes-Benz genuine engine oils.

¹ Information about the rated output according to Regulation (EC) No. 715/2007 in the currently valid version. ² Available temporarily. ³ Electronically governed. ⁴ The stated figures were determined according to the prescribed measurement method. They constitute the "NEDC CO₂ figures" pursuant to Article 2 No. 1 Implementing Regulation (EU) 2017/1153. Fuel consumption figures have been calculated on this basis. More information about the official fuel consumption and the official specific CO₂ emissions of new passenger cars is available in the publication entitled "Leitfaden über den Kraftstoffverbrauch, die CO₂-Emissionen und den Stromverbrauch neuer Personenkraftwagen" ["Guidelines concerning the fuel consumption, CO₂ emissions and electricity consumption of new passenger cars"], available free of charge at all retailers and from Deutsche Automobil Treuhand GmbH (www.dat.de). The figures are not based on an individual vehicle and do not constitute part of the product offer; they are provided solely for purposes of comparison between different vehicle models. The figures will vary according to the optional equipment selected. ⁵ Information only valid within the European Union. May vary from country to country. ⁶ Determined on the basis of the measured CO₂ emissions, taking into consideration the vehicle mass. Only valid for Germany.

Further technical data may be found at www.mercedes-benz.com.cy

Dimensions.

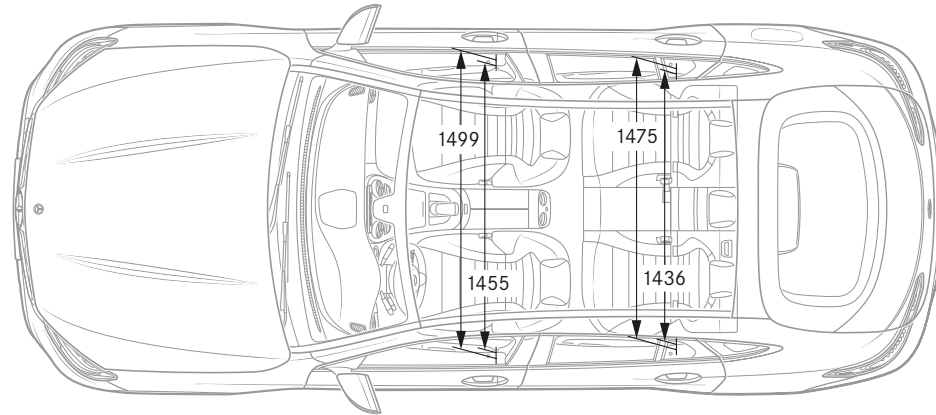
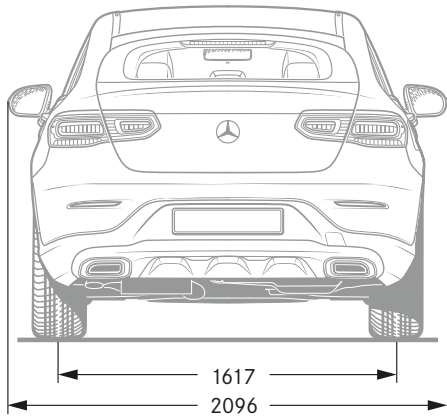
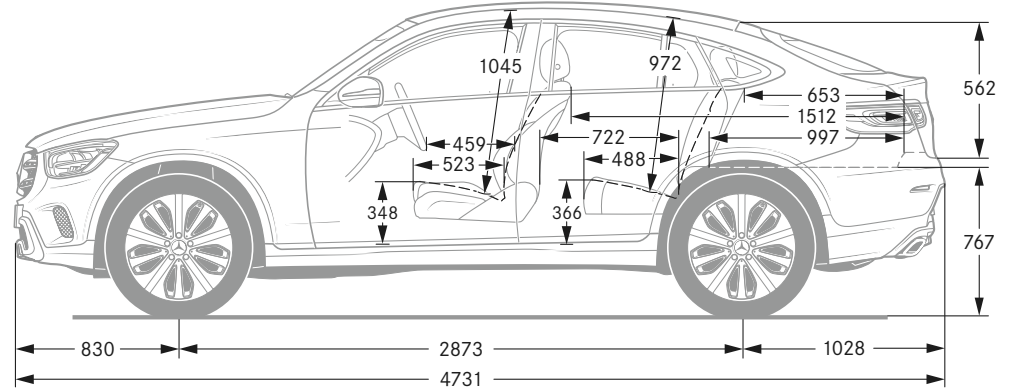
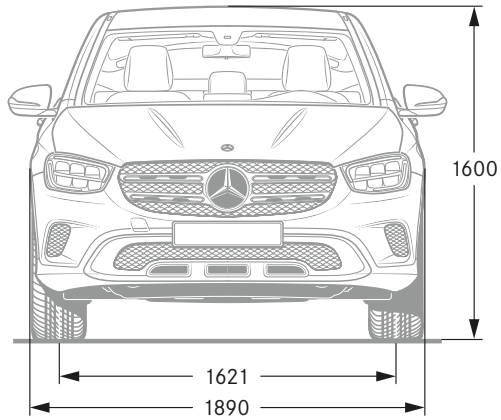

All figures in millimetres. The pictured dimensions are mean values. They are valid for vehicles in basic specification and in unladen condition.



SPORT - F O R - GOOD

Mercedes-Benz AG is one of the founding partners of the worldwide "Laureus Sport for Good Foundation", which was established in 2000. It is the Mercedes-Benz brand's most important social initiative. Laureus Sport for Good supports children and young people in need through social sports projects, opening up new perspectives and imparting important values such as team spirit, respect and determination. "Change the Game for Kids" is our mission statement which we wish to share with you.

Please note: Changes may have been made to the product since the editorial deadline on 03.09.2020. The manufacturer reserves the right to make changes to the design, form, colour and the product specification during the delivery period, provided these changes, while taking into account the interests of the seller, can be deemed reasonable with respect to the buyer. Where the seller or the manufacturer uses symbols or numbers to describe an order or the

subject of an order, no rights may be derived solely from these. The illustrations may show accessories and items of optional equipment which are not part of standard specification. For the definitive latest information, please contact your nearest authorised Mercedes-Benz AG dealer.