

The A-Class Compact Saloon



Mercedes-Benz



Hey Mercedes.

Have you ever been in this situation? You meet someone and have the feeling you have always known them. That's almost what it's like with the A-Class. You were only introduced to each other a few days ago and yet the vehicle is familiar with your preferences, your moods, and with what you like and dislike. It almost knows you better than you do yourself. The A-Class and you suddenly become one. So you can always be your true self.





A dark grey Mercedes-Benz A-Class car is parked on a city street. The car is shown from a rear three-quarter view, highlighting its sleek design and multi-spoke alloy wheels. The background features a modern building with a grid of windows and a street lamp, suggesting an urban environment. The lighting is soft, creating a sophisticated atmosphere.

Really looks good on you.

The lines of the A-Class all follow one direction only: our design philosophy of Sensual Purity. Surfaces are even more puristic, details even more striking. Very neat, right?



D S W1772



May we be of assistance?

That's what our connectivity services are all about. Making life easier. Wirelessly, without the need for keys, the A-Class connects completely effortlessly to everything that is important to you.



Let's talk about trust.

Your A-Class can warn you of an impending collision, support you when braking and taking evasive action, or even autonomously brake the vehicle to a standstill in an emergency.





The A-Class.

With Mercedes *me*







Safety and assistants.

State-of-the-art protective instinct. The A-Class can even maintain a distance at speeds up to 210 km/h.¹ Thus reducing its own from the luxury class. You can trust its senses (it really has them) like no one else's. Even at high speeds. With the help of Active Distance Assist DISTRONIC it will help you maintain a safe distance from the vehicle ahead of you. Active Brake Assist can brake autonomously in an emergency. As a result, you feel safe and in good hands at all times. Can a car do more for you?



Ambient lighting.

Showcase the interior according to your personal preferences or current mood. The 64 colours of the ambient lighting create fascinating colour schemes, for example in the illuminated ventilation outlets, the doors or the dashboard.

¹ The top speed depends on the engine chosen.



MBUX Augmented Reality for Navigation.

Gain completely new insights thanks to the A-Class. Into the road, for example. The system uses a special camera to depict the surroundings as a moving or still image on the multimedia system's display – in an innovative and informative way. It supplements virtual objects or markings and thus facilitates finding your destination. It's all totally intuitive, and pretty intelligent too.



Connectivity.

In the A-Class you can charge your smartphone by placing it in the centre console. Simple, without the need for cables and based on the Qi standard. And the best thing: thanks to near-field communication (NFC), your smartphone immediately connects to the A-Class Saloon without lots of intermediate steps.

Sending text messages or scrolling through contacts is also no problem at all. You can use your smartphone in the A-Class without having to pick it up. Use USB, WLAN or NFC to connect to the vehicle. Then conveniently control almost all apps and functions via the multimedia system display using the Touch Control buttons on the steering wheel. As if by magic.



“Wrap-around” design.

The interior of the A-Class practically hugs its occupants. Smooth transitions between instrument panel, centre console and door trims create the pleasant wrap-around design. This is just as exceptional in this class of vehicle as the choice of trim elements and the ambient lighting, which showcases every detail so perfectly.

Widescreen vision.

Here one glance says more than a thousand words. The interior of the A-Class looks completely different and you will see things in a new light as a result. Not just on one, but on two high-resolution displays, with a screen diagonal of 17.78 centimetres (7 inches) as standard. Or optionally extra-large, at 26 centimetres (10.25 inches). In either case, the screens appear to be floating within the interior. They are also extremely easy to operate via the steering wheel, the touchpad or the touchscreen. The latter represents an additional world-first that is definitely worth another look.



Leather multifunction sports steering wheel.

The elegant leather finish gives the multifunction sports steering wheel an even higher-quality look, making it a true highlight of the interior. As the driver you benefit on two counts: something that looks good must also feel good.



Media display.

The large high-resolution media display (10.25 inches) networks you with the car. It has a touch-sensitive screen. Symbols make operation easier and improve concentration. An aesthetic delight: the media display and the larger instrument display combine to create a Widescreen Cockpit.

Standard equipment and appointments.

You already get a great deal of A-Class without selecting a single item on the options list. Indeed, the vehicle has a lot to offer in its standard specification. The brand's hallmark high standard of safety is exemplified by Active Brake Assist and Active Lane Keeping Assist. The air conditioning system provides for your desired climate.



The Style design and equipment line.

With the Style design and equipment line your car stands out from the standard equipment. A youthfully cool look inside and out. This includes additional features such as the 16-inch light-alloy wheels, plus upholsteries and topstitching in trendy colours which are exclusive to the line.



The Progressive design and equipment line.

The Progressive design and equipment line substantially enhances your car. Added value you can see and feel. From every perspective the excitement and high-quality engineering associated with a premium compact car is intensified.



The AMG Line.

With the AMG Line you are making a clear statement about performance. The AMG bodystyling with special front and rear aprons, in particular, lends the car a resemblance to AMG models. In addition, technical features such as a lowered, sportily tuned suspension and the Direct-Steer system serve to intensify the driving experience.





DYNAMIC SELECT.

Just drive as you want to. At the press of a button DYNAMIC SELECT offers different drive programs with setting options for the engine, transmission, suspension and steering, for instance. In "Sport" mode the vehicle is more dynamic, while in the standard "Comfort" mode its set-up is exceptionally balanced. "ECO", meanwhile, places the emphasis on maximum efficiency and saves fuel and money.

The "ECO" drive program gives you especially comprehensive support if you want to avoid CO₂ and pollutants. The seat heating and air conditioning work with reduced output in this setting and thus also save valuable energy. In "Individual" you choose all the respective parameters yourself. This means that you can select a sporty setting for the drive system and at the same time have a comfortable setting for the suspension.

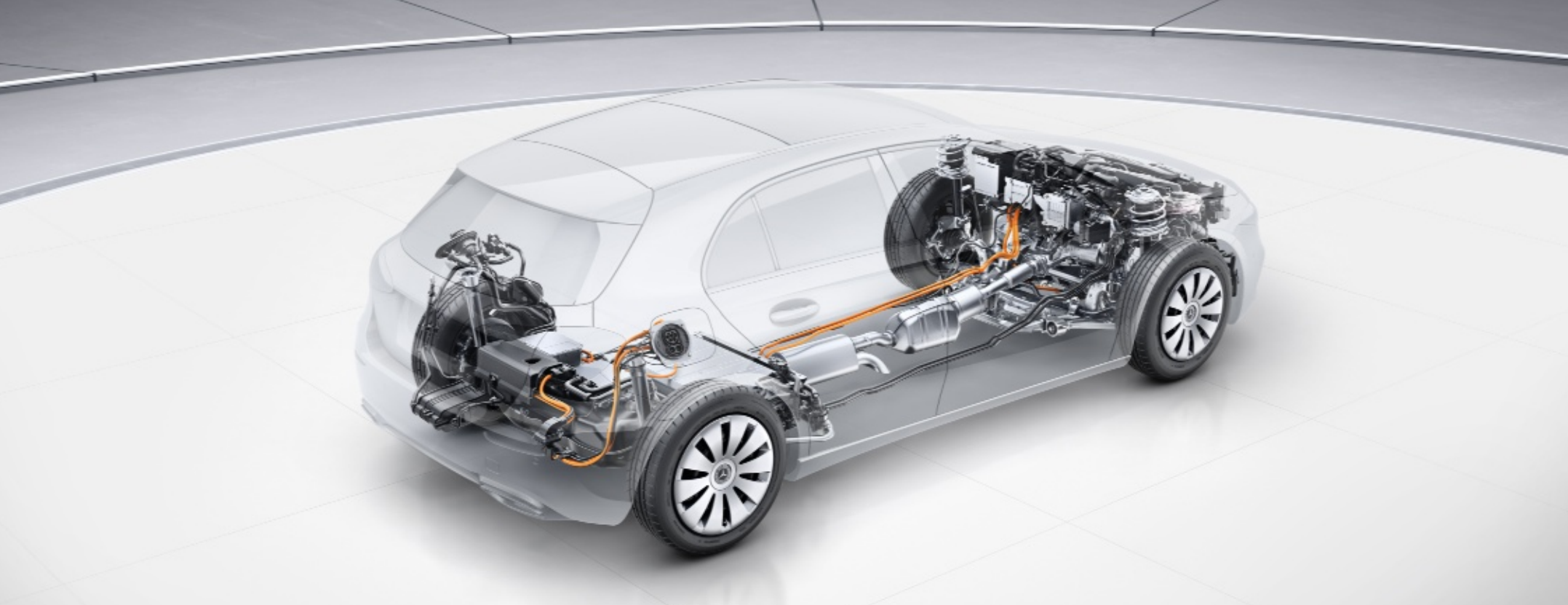

Discover the first A-Class with plug-in hybrid technology.

The engines incorporate advanced technology which manifests itself in increased power and improved performance. A crucial factor here is the combination of cutting-edge technological components with a host of detailed individual

measures. This can be experienced particularly well in the A 250 e: the first plug-in hybrid in the A-Class Saloon.

Instant performance.

A Mercedes-AMG is a clear statement. One you can experience with all the senses. An experience you consciously choose to have. Whether it's design or output, form or function: every one of our vehicles expresses passion for perfection and performance in sound, style and joie de vivre. Driving a Mercedes-AMG is an expressive experience you want to repeat over and again. A perfect symbiosis of performance and style. With a Mercedes-AMG you are guaranteed to make a powerful impression with no compromises.

It is time for your AMG experience!

www.mercedes-amg.com



AMG



Technical data.

	Petrol engines					Plug-in hybrid	
	A 180	A 200	A 250	Mercedes-AMG A 35 4MATIC	Mercedes-AMG A 45 4MATIC+	Mercedes-AMG A 45 S 4MATIC+	A 250 e
Displacement (cc)	1.332	1.332	1.991	1.991	1.991	1.991	1.332
Rated output ¹ (kW [hp] at rpm)	100 [136] / 5.500-5.500	120 [163] / 5.500-5.500	165 [224] / 5.500-5.500	225 [306] / 5.800-5.800	285 [387] / 6.500-6.500	310 [421] / 6.750-6.750	118 [160] / 5.500-5.500
Acceleration from 0 to 100 km/h (s)	9,2	8,2	6,2	4,7	4	3,9	6,6
Top speed (km/h)	215	225	250 ³	250 ³	250 ³	270 ³	235
Fuel consumption ⁴ (l/100 km)							
Urban	7,3-7,0	7,4-7,0	8,3-8,1	10,0-9,9	10,7-10,6	10,7-10,6	
Extra-urban	4,6-4,3	4,6-4,3	5,1-4,9	6,6-6,4	7,0-6,9	7,1-6,9	
Combined	5,6-5,3	5,6-5,3	6,3-6,0	7,8-7,6	8,4-8,3	8,4-8,3	1,5-1,4/13,6-11,9
Combined CO ₂ emissions ⁴ (g/km)	128.0-121.0	128.0-121.0	144.0-138.0	179.0-174.0	192.0-189.0	192.0-190.0	35.0-31.0
Emissions class ⁵ /efficiency class ⁶	EURO 6D-ISC- FCM / B	EURO 6D-ISC- FCM / B	EURO 6D-ISC- FCM / C	EURO 6D-ISC- FCM / D	EURO 6D-ISC- FCM / E	EURO 6D-ISC- FCM / E	EURO 6D-ISC- FCM / A+
	Diesel engines						
	A 180 d	A 200 d	A 220 d				
Displacement (cc)	1.950	1.950	1.950				
Rated output ¹ (kW [hp] at rpm)	85 [116] / 3.400-4.400	110 [150] / 3.400-4.400	140 [190] / 3.800-3.800				
Acceleration from 0 to 100 km/h (s)	10	8,6	7				
Top speed (km/h)	202	220	235				
Fuel consumption ⁴ (l/100 km)							
Urban	6,5-6,2	6,2-6,1	5,7-5,5				
Extra-urban	4,0-3,8	4,0-3,8	4,0-3,8				
Combined	4,9-4,7	4,8-4,6	4,6-4,4				
Combined CO ₂ emissions ⁴ (g/km)	128.0-123.0	127.0-123.0	121.0-116.0				
Emissions class ⁵ /efficiency class ⁶	EURO 6D-ISC- FCM / B	EURO 6D-ISC- FCM / B	EURO 6D-ISC- FCM / A				

¹ Information about the rated output according to Regulation (EC) No. 715/2007 in the currently valid version. ² Available temporarily. ³ Electronically governed. ⁴ The stated figures were determined according to the prescribed measurement method. They constitute the "NEDC CO₂ figures" pursuant to Article 2 No. 1 Implementing Regulation (EU) 2017/1153. Fuel consumption figures have been calculated on this basis. More information about the official fuel consumption and the official specific CO₂ emissions of new passenger cars is available in the publication entitled "Leitfaden über den Kraftstoffverbrauch, die CO₂-Emissionen und den Stromverbrauch neuer Personen-kraftwagen" ["Guidelines concerning the fuel consumption, CO₂ emissions and electricity consumption of new passenger cars"], available free of charge at all retailers and from Deutsche Automobil Treuhand GmbH (www.dat.de). The figures are not based on an individual vehicle and do not constitute part of the product offer; they are provided solely for purposes of comparison between different vehicle models. The figures will vary according to the optional equipment selected. ⁵ Information only valid within the European Union. May vary from country to country. ⁶ Determined on the basis of the measured CO₂ emissions, taking into consideration the vehicle mass. Only valid for Germany. * Weighted electrical consumption (kWh/100 km)/Electric range (km): 1.5-1.4/78-73.

Dimensions.

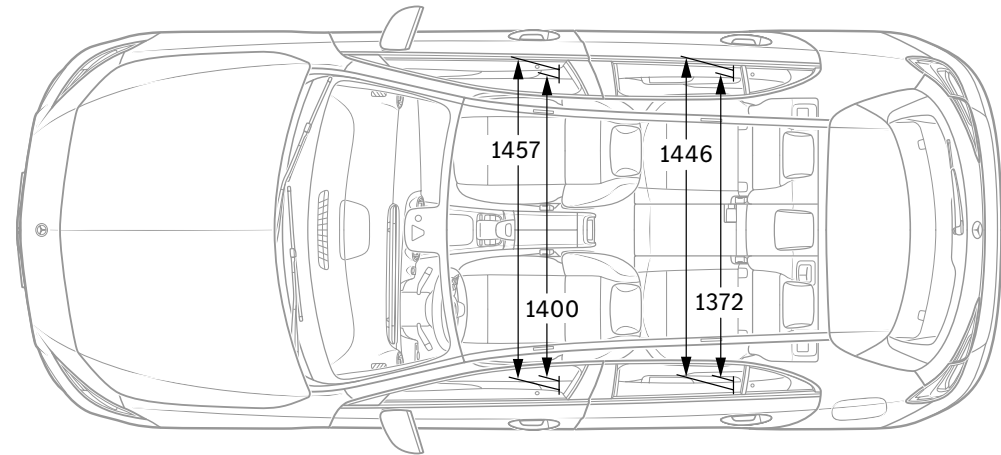
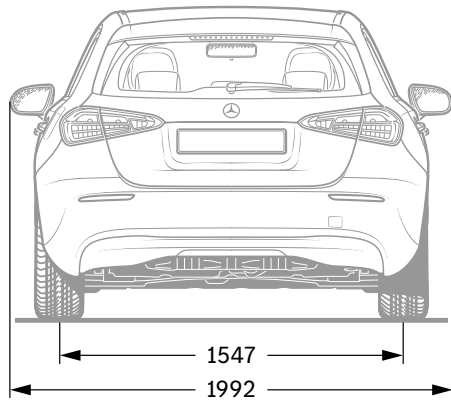
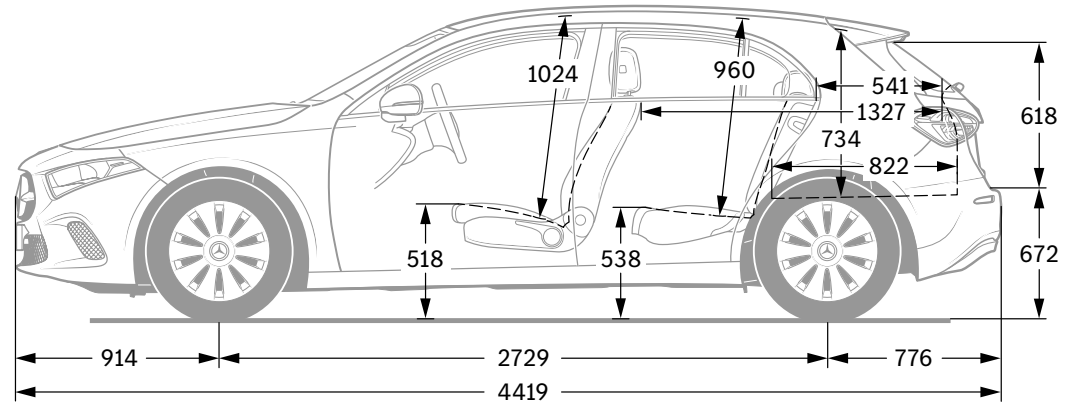
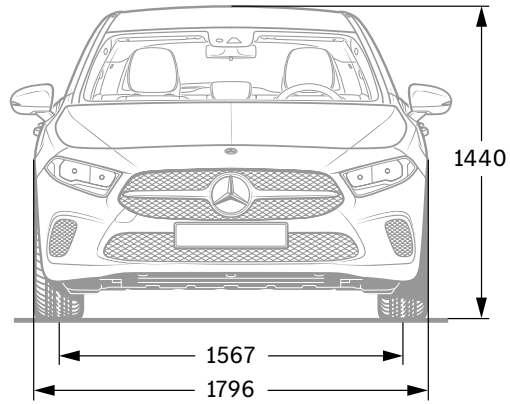

All figures in millimetres. The pictured dimensions are mean values. They are valid for vehicles with standard equipment and in unladen condition.



SPORT — F O R — GOOD

For 20 years now it has been our belief that sport has the power to connect people and motivate them in a unique way. We have facilitated urgently needed access to our support programmes for millions of children and young people, so helping them to achieve positive change in their lives. The programmes that we support together with Laureus Sport for Good are in line with the United Nations' Sustainable Development Goals and are part of an exciting major global movement to effect positive change in the world.

Please note: Changes may have been made to the product since the editorial deadline on 25.06.2021. The manufacturer reserves the right to make changes to the design, form, colour and the product specification during the delivery period, provided these changes, while taking into account the interests of the seller, can be deemed reasonable with respect to the buyer. Where the seller or the manufacturer uses symbols

or numbers to describe an order or the subject of an order, no rights may be derived solely from these. The illustrations may show accessories and items of optional equipment which are not part of standard specification. For the definitive latest information, please contact your nearest authorised Mercedes-Benz AG dealer.